

9

Portfolio Prioritization

In Chapter 1, the core goals of the PMO were defined as maximization, balance, and alignment [1, 2]. The portfolio should be maximized against some corporate goal such as profitability, it should be balanced across several dimensions (most commonly across risk versus reward), and it should be aligned with the business unit's and ultimately the company's strategy. Most methods for prioritizing initiatives have focused on maximization and strategic alignment. These methods rank initiatives and projects against each other by assigning scores. Balancing the portfolio, on the other hand, may require some initiatives with lower ranks to be approved for funding. With financial systems, the portfolio analysis begins with weighting individual securities for risk and return. It ends with conclusions concerning portfolio balance as a whole [3]. The conclusions that an IT PMO needs to provide to the executive committee are that the balance of chosen projects provides the optimal vector (time and scope) of growth the committee desires.

9.1 The Prioritization Process

In previous chapters, we showed how a company can promote new ideas by effectively capturing and then presenting both externally and internally generated knowledge. We also showed how the IT PMO provides support to the idea creators in the form of early risk assessments and business case templates. Yet, how can idea creators feel confident that their ultimate business cases will be reviewed fairly and consistently against other proposals? The IT PMO, along with the executive team, needs to first create a review process and then communicate it to the staff. They need to balance between a culture in the enterprise that encourages innovative ideas and an environment that ensures rigorous strategic assessments [4]. With visibility into how initiatives are prioritized and then approved as projects, business case writers will feel safe that their hard work will get the due diligence it deserves.

But before a review process can be effective, it needs a solid initiative methodology that serves as the incoming pipeline of new business cases. If such a methodology isn't clearly defined, then the review committee will be spending most of its time wading through worthless ideas and indecipherable template formats. The following elements were presented in previous chapters as necessary components to build the pipeline that will allow the review committee to spend time where it is most needed: prioritizing initiatives and projects. The IT PMO will need to make sure that [5]:

1. The strategy, the EBA, and the EIA were developed.
2. An IT initiative review methodology was created and communicated.
3. Minimal acceptance criteria (early hurdles or gates) were established.
4. Business case templates were posted.

Two different review teams will be established by the IT PMO to run two ongoing prioritization review processes: the IT initiative review and the IT project audit processes. Where initiative reviews are held to determine the selection and resourcing of a project, project

audits are held in terms of the project's timetable and milestones to determine ongoing health and alignment [6, 7]. In both cases, each team will compile, as a group, the results of its reviews into a central project prioritization list to be presented to the executive review committee. Such group decision processes have been found to work best in top-performing businesses when creating prioritization lists [8]. Sometimes, referred to as the *murder boards* [9], these teams' powers are similar to those of a congressional subcommittee: if they "prioritize out" an initiative, then the central floor (executive review committee) will never see it.

When developing the prioritization criteria, it is widely accepted that the selection process should be based on multiple criteria [3]. Initiatives should be evaluated against a standard set of criteria that include both quantitative measures, such as value-creation potential, sales cycle time, and human resource requirements, and qualitative measures, such as consistency with the company's strategy [10]. Because both the quantitative and the qualitative measures are based on speculation, initiative reviews can only be graded on the return the business case expects to see by a certain future date. Once the project begins, however, quantitative measures can become more objective and less subjective. Therefore, when presenting an initiative for selection, it would be best to calculate the measurement criteria as ranges, or small bell curves of uncertainty, rather than as single point forecasts to describe future possibilities. "Using ranges enhances credibility by avoiding false precision" [11].

"Within the context of software project management, we are concerned primarily with *productivity and quality metrics*" [12]. However, within the context of aggregate project health and real-time IT strategic alignment, we are concerned primarily with initial estimate and corporate strategy alignment. If the schedule, cost, or resource needs vary (become unaligned) from the original estimates by a certain amount at a given time, then the project should be considered riskier than a project that is in agreement with original estimates. The other side of the coin is the more qualitative alignment of the project with the corporate strategy. If either the corporate strategy has shifted or a project has scope crept, the project can be at risk of not satisfying exactly what the

company needs. The addition of such quantitative and qualitative project metrics help the IT PMO better understand the health of the portfolio.

When developing the prioritization process, be sure the selection criteria are simple to use and are tailored to your specific company. Most portfolio selection models imply “a degree of precision far beyond people’s ability to provide reliable data” [2]. While a robustly defined selection method may produce results trusted by decision makers, it can result in too much complexity to be usable [13]. For example, larger companies with more entrenched processes and cultures tend to find that the qualitative measures of organizational and cultural fit are often more important. On the other hand, smaller, newer companies with more limited capital resources and nascent organizational structure find that quantitative measures of capital funding or near-term cash flow usually matter more (see Table 9.1) [10].

9.2 Initiative Reviews

Figure 9.1 shows an example of an IT initiative review process. In this case, we start with the ideas that, in turn, materialize as initiative business cases. Before documenting the proposal as a business case, however, the IT PMO provides organizational and technical information specific to the company (e.g., the EBA and the EIA). This allows the idea

Table 9.1
Needs for Qualitative Versus Quantitative Progress Measures
for Large and Small Companies

	<i>Qualitative Measures</i>	<i>Quantitative Measures</i>
Old/large company—large portfolio (entrenched processes and cultures)	Organizational and cultural fit—more important	Robust hurdle rate processes (e.g., NPV, IRR, PB) already in place
New/small company—small portfolio (limited capital resources, nascent organizational structure)	More seat of the pants due to limited time and resources	Capital funding or near-term cash flows—more important

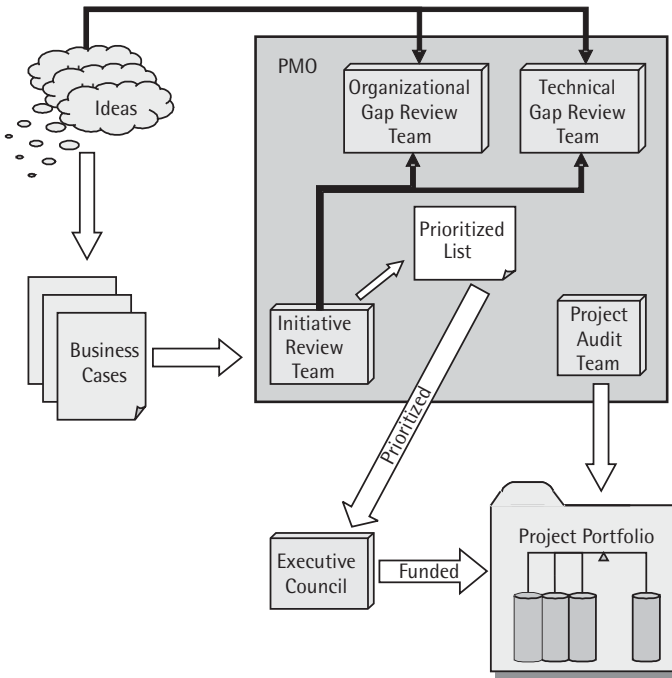

Figure 9.1 Initiative review process flow of an IT PMO using prioritized lists.

generator to be sure that the idea is well aligned. This information can be incorporated into the business case to help boost its eventual rating against other competing business cases. When prioritizing initiatives, the IT PMO also leverages the organizational and technical gap review processes to get a clearer picture of the relative risks of the different initiative proposals. The prioritized list ultimately goes to the executive council to help it determine which projects to fund.

Another example of an IT review process is shown in Figure 9.2. Here, “portfolio selection uses project evaluation and selection techniques in a progression of three phases: strategic considerations (alignment), individual project evaluation (maximization), and portfolio selection (balance)” (see Figure 9.2) [14]. In the previous example, we enhanced this first phase of *prescreening* to include not just strategic alignment review, but also organizational and technical risk/gap analysis. Specifically, we checked to see if the initiative would be organizationally and technically deliverable. In this example, the second major

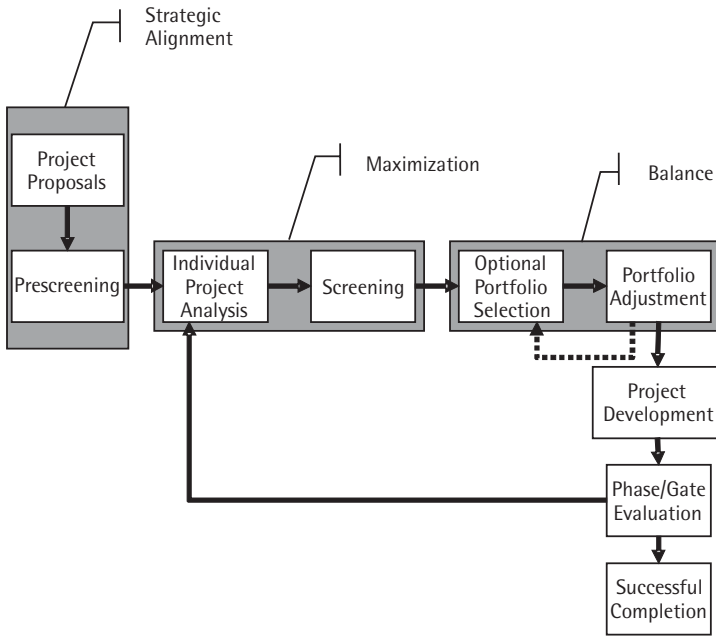

Figure 9.2 When to apply strategic alignment, maximization, and balance during the initiative review process. (After: [14].)

step would be to rank the initiatives against each other. The initiatives with the maximum summation of some core set of values such as profitability, strategic alignment, or cost reduction will be ranked highest. Also, interactions between the projects (e.g., interdependencies, competition for resources, and timing) are considered [14]. Finally, the last step focuses on the balance of the portfolio. Here, some projects that show a higher ranking may be rejected in favor of a project that supports a long-term balanced strategic direction.

Earlier, we explained the initiative methodology process that wraps around the core initiative review process. The pipeline feeding the initiative review committee is supported by predefined strategies, architectures, knowledge bases, and business case templates. The pipeline that allows initiatives to begin as projects is supported by efficient review processes and dependable resource management processes. We already found that poor resource acquisition can clog the initiative output pipeline. Yet, how does an inefficient selection process contribute to this

malaise? Sometimes, the executive review committee may hold funds until it gets research results from the organizational and technical gap processes of the IT PMO. If this happens, other time-dependent initiatives can get backlogged, waiting for these same funds. One approach could be that a project “could remain on hold for no longer than three months. After that, it is ‘up or out’” [2]. Many times, companies lack such gates, and the result is frustrated initiative proposers, unnecessarily waiting for limited funds. On the other hand, other companies that have such gates can impose them too rigorously and fail to give initiatives the complete review they need before rejection or approval. Such balancing between the need for gates and robust initiative reviews, coupled with ongoing resource management, will allow the IT PMO to keep the output side of the IT initiative methodology flowing with dependable projects.

IT initiative prioritization is an important step in managing a solid IT PMO. However, “despite widespread recognition of the front end’s importance, there has been limited systematic examination directed at improving its effectiveness” [15]. For an initiative prioritization (filtering) process to be effective, it first has to be measured. While initiative reviews show how to best prioritize the initiatives, project audits focus on how to best measure the initiative’s success. The metrics chosen to rank initiatives need to be well correlated with, or identical to, the metrics used to verify project ROI. If this is done, the PMO can trace the effectiveness of an initiative prioritization process all the way down to the aggregate project success level of the IT PMO.

9.3 Project Audits

The project audit review team provides the second source of data for the central IT-based project prioritization list. Figure 9.3 shows how the PMO can conduct organizational, technical, and cross-project gap reviews to update the prioritization lists for the executive committee. Then, funding can continue to go to those projects that are healthy and in alignment with the corporate strategy. While reviewing and prioritizing initiatives is necessary to better distribute funds, it isn’t very easy to take funds away from a project that is reviewed poorly. Projects have the

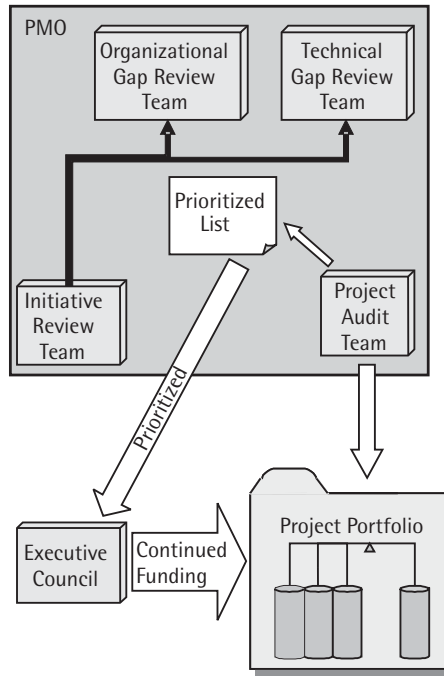

Figure 9.3 Project audit process flows of an IT PMO.

added benefit of momentum—it can be more costly to cancel a problematic project and redistribute the resources than it would if the project were allowed to continue to completion. Nonetheless, the IT PMO audit team needs to quickly find those projects that are spiraling so far out of control that even any future real options have become unattractive. A substantial reduction in wasted development expense can be realized if projects are killed early in their lives [16]. To help stakeholders remove the “horse blinders” they tend to wear on doomed projects, their projects should be reviewed when they reach major milestones, or gates. Running projects should be “re-evaluated at the same time as new projects being considered for selection” [14]. Though the cost of project cancellation should always be included as part of the prioritization calculation, the fact that they are being included in the prioritization list with initiatives helps enhance the view of the IT PPM process in the eyes of the executives [17].

It is important that the project review process be only for review, rather than a platform for micromanaging projects. The IT PMO exists to support projects so that they will be individually successful. As the portfolio of projects, on average, shows improvement, then the project support goals of the IT PMO will have been achieved. If, on the other hand, upper managers or the IT PMO “are held absolutely accountable for the success of every project, it is unlikely they will grant the autonomy that project managers need” [18]. In fact, such an approach could actually degrade the performance of each project and thus the health of the portfolio. “Responsibility for defining a) the tie to strategy and b) interdependencies rests in the hands of the project sponsor and project manager” [19].

This is a particularly sensitive piece of the PMO. The audit team should focus on being an aid rather than a hindrance to a project. The PM should be made aware of how the audit team will be grading the project’s health before the audit. Then, while auditing, the audit group should focus on how a project is proceeding rather on the content of the project. For example, if a project has gathered requirements from a set of user interviews, the audit team should focus on giving higher marks for following the interview-to-requirements process rather than lower marks for the quantity or content of the requirements. Grading of content should fall to the PM and to the stakeholders. If the PM has failed to conduct a requirements review with the stakeholders, and the stakeholders have failed to read up on what is considered a quality set of requirements, then the audit team can give lower marks.

When can an IT PMO be most supportive to projects during the audit process? Figure 9.4 shows an example timeline for when such measurements can be taken in the life cycle of a project with three iterations. As can be seen, measurements are taken at the end of each phase within an iteration. In this case, the IT PMO has come up with a set of audit “kits” that can be used on different phases. By modularizing (or in software-speak, objectizing), the audit team has created standard methods for addressing different parts of the auditing process. If changes need to be made, they can be applied to one of these subaudit kits rather than redeveloping one large audit methodology. Figure 9.4 shows four examples of such kits and when they would be used for auditing:

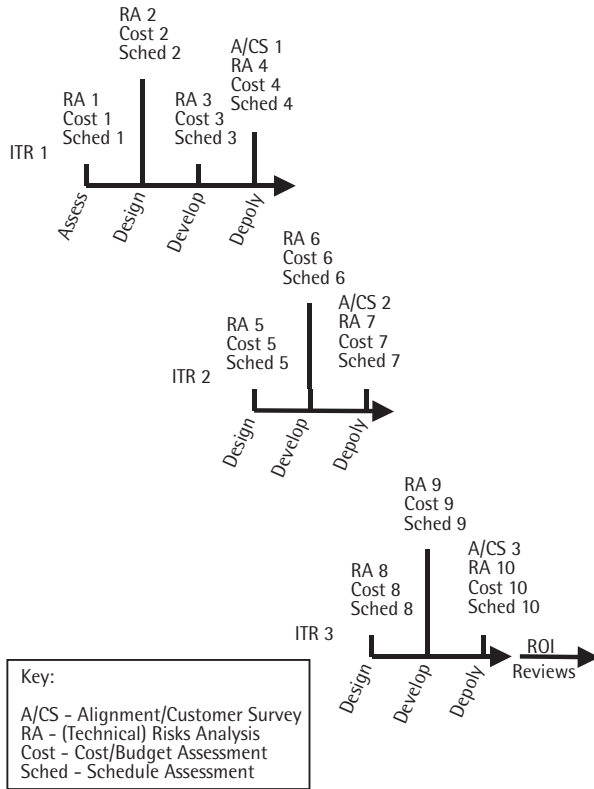

Figure 9.4 When to apply certain predefined audits to a project's timeline.

alignment and customer survey, technical risk analysis, cost/budget assessment, and schedule assessment. As can be seen, these kits were built around the project triad and risk, as introduced in Chapter 2. Such audits are more critical in the early phases of a project because “as the project moves through its life cycle, the ability to influence the outcome of the project declines rapidly” [4]. So, with early surgical audits, the IT PMO can support problematic and flag doomed projects before they drag the company away from its strategic direction.

9.4 Portfolio Maximization

Metric mapping was introduced earlier as a way to verify ongoing project health by linking initial metric projections made in the business case

to reality. Let's now look at how such metrics can be chosen by the project sponsor and the PM to show continued value maximization. Because IT projects, like human beings and their personalities, are impossible to clone, a metric set should be chosen to best fit the personality of a given project. Understand what the original motivation was for measuring a part of a project's progress, and "apply measurement to those value areas" [20]. But, how can a central body measure and compare IT project health if every project team is grading itself using different standards? With timelines squeezing and deliverables lists growing, today's IT PM has little time to gather, let alone gather accurate, project metrics. They have enough pressures from stakeholders and team members to worry about before worrying about the process demands of some outside party. However, PMs, like the executive team, need to realize that IT projects should be treated as any other strategic investment where risk monitoring methods should be in place. We assert that if the project metrics are minimized in scope, released carefully, and used effectively, metric tracking from initiative proposal to project ROI will be successful.

Minimize in Scope

Dr. Markowitz defines some rigorous mathematical formulas to monitor and mitigate risk when managing a financial portfolio. Each security's entry in a portfolio must submit to the same risk-monitoring scrutiny that other securities do. So, to accommodate the MPT expectations of the executives and the time pressures of the IT PMs, a middle ground should be defined for an IT project portfolio. While the metric set should be kept small enough not to disrupt ongoing project momentum, it should be robust enough to provide accurately representative reports.

Release Carefully

The Meta Group of Stamford, Connecticut, asserts that IT valuation metrics should be introduced in phases. If the PMO can get PMs to regularly maintain a bare minimum of metrics, the first step to IT valuation will be accomplished. More metrics can be rolled out in later phases once the initial metrics have been embraced by PMs. A good general rule when choosing initial valuation metrics for the portfolio of

projects would be to include two quantitative metrics (e.g., budget and schedule) and two qualitative metrics (e.g., business results and risk management). As the project management staff adopts the use of these metrics, the PMO can phase in other metrics that address delivery processes, asset management, and human resources.

Apply Effectively

PMs should understand that the business case describes their project deliverables in terms of the benefits that would be created for the organization. Thus, “with deliverables defined as benefits to be harvested, project tracking should be focused on deviation from delivery of those benefits” [19]. This is why financial measures and customer sign-offs should be just as much a part of the audit as lines of code or function points. As the project progresses, this latter form of internal programming measures produce diminishing returns while financial measures become more relevant [21]. Alternatively, with individual projects, value does not come from improving the results of individual metric measures; rather, it comes from “linking changes in such measures to customer and financial outcomes” [22]. For example, if the earned value analysis of the project in midstream showed marked improvement over a previous measure, this wouldn’t add to the value of the project until such a measure could be linked to the combination of ultimate financial outcomes and customer satisfaction. With the portfolio, as a whole, value comes from “the value-enhancing actions that are taken as a consequence of the analysis” [23].

9.4.1 Metrics

When developing the business case templates, the IT PMO review committee will also establish some minimum acceptance hurdles, or gates. These gates can be defined using certain economic models, such as IRR and NPV (the accompanying CD-ROM contains several ROI tools that can be used for this). Then, as the EBA and the budgets shift, the IT PMO can raise or lower these gates to fit changed EBAs or to meet new budget restrictions. When comparing the initiatives for approval, the review teams can use other analytical approaches, such as mathematical

programming, decision analyses, and interactive/comparative methods (see Table 9.2). Whichever metrics are used, the project sponsor will ultimately be held accountable for the metrics hurdles they overcame in the initiative review process. In the final project audit, the IT PMO will need to link final metric results back to the financial or customer/user satisfaction goals of the business case.

The following four generic methods list some approaches to tracking these metric areas [5, 13, 24]:

- ♦ *Mathematical programming*—Integer programming, linear programming, nonlinear programming, goal programming, and dynamic programming;
- ♦ *Economic models*—IRR, NPV, PB period, ROI, cost-benefit analysis, option pricing theory, average rate of return, and profitability index;
- ♦ *Decision analysis*—Multiattribute utility theory, decision trees, risk analysis, analytic hierarchy process, unweighted 0–1 factor model, unweighted $(1 - n)$ factor scoring model, and weighted factor scoring model;
- ♦ *Interactive comparative models*—Delphi, Q-sort, behavioral decision aids, and decentralized hierarchical modeling.

Not only does this list show how many types of prioritization techniques exist, it also shows how “there is no universal method, dominant theme or generic model” [2]. Rather, the methods and how they are

Table 9.2
Categories of Metrics to Use in IT-Based Business Cases

	<i>Metric Area</i>	<i>Examples</i>
1	Productivity/efficiency	Amount of work completed and amount of time to complete it
2	Quality/effectiveness	Business goals achieved and risks overcome effectively
3	Delivery process	Delivery percentages, backlog costs, rework costs
4	Asset management	Asset portfolio sizes, costs, and distributions
5	Resource management	Turnover and work hour statistics, staff sizes, and costs

grouped tend to be very firm specific. For example, when choosing the minimum acceptance gate metrics for business case submission, it is recommended that the IT PMO look at those used most frequently by their financial department. Aligning these metrics with the internally accepted methods for managerial accounting will help establish IT PMO credibility with the financial department [25].

The metrics used in this list are used to rank order projects against each other to determine which ones offer the greatest return. Mathematical programming and economic models (shown in Chapter 2) provide the calculations that can then be used in the decision analysis and comparative models (real options analysis in Chapter 2 is an example). While such rank ordering of projects and initiatives guarantees a portfolio of high value (or return) projects, there are problems with using only this method of prioritization. For example, if permitted, PMs will tend to manage to short-term financial gains at the expense of long-term benefits (e.g., growth, customer focus, innovation, and employee empowerment) [22]. Moreover, because these types of measures are based on subjective projections, they can be unreliable. Because these unreliable measures tend to be used at the beginning of an initiative, resource-need calculations can be flawed. Ultimately, because such things as defect-free quality and customer satisfaction may not be measured, these narrow-focused financial metrics can cause the portfolio and the associated resource usage to become unbalanced and unaligned [22, 26]. They can end up being so complicated that the PMs won't even use them [27]. While financial measures, on their own, can instill a false sense of project health, if measured consistently across all projects, they give the project sponsors a sense of the relative value of project deliverables.

The business case writer can select metrics beyond the minimal set required by the IT PMO. Taken together, the initiative's metric set should be well rounded to ensure project success. The Meta Group suggests that metrics be chosen from each of the five areas shown in Table 9.2.

Delivery process metrics will help the IT PMO gauge whether the portfolio's health is improving, and asset and resource metrics can be compiled from each project to verify whether the IT PMO is being

successful with AARK management. With the first two metric categories, we can begin to see the relation to the project triad and risk analysis presented in Chapter 2 (see Table 9.3).

Robert G. Cooper, Scott J. Edgett, and Elko J. Kleinschmidt, three marketing professors from McCaster University, conducted a groundbreaking survey of 205 responding companies on PPM. The survey asked each company which PPM metrics, out of the following six, they used the most in prioritizing their project portfolio. The metrics tested whether:

1. The projects were aligned with business objectives (*EBA alignment*).
2. The portfolio contained *very-high-value* projects.
3. Spending reflected the business's strategy (*budget/strategy alignment*).
4. Projects were done *on time* (i.e., no gridlock).

Table 9.3
How the Project Triad Affects Metric Choices

<i>Metrics Chosen</i>		
<i>Productivity/efficiency</i>	Performance to budget (cost)	Measures how actual interim costs are mapping to predicted interim costs.
	Performance to schedule (time)	Maps predicted interim delivery timelines to actual interim delivery timelines.
<i>Quality/effectiveness</i>	Delivery of business results (functionality)	Qualitative measure of how well the interim project results are mapping to shifting business and strategic goals.
	Risk analysis	Each project can list its greatest five risks at the beginning of the project and then track them through the project's lifetime. The number of risks monitored is up to the PM, but a PMO should require some summation of the risks as another metric to help rate the project against other projects.

5. The portfolio had a good *balance* of projects.
6. The portfolio had the *right number* of projects.

They found that the businesses that scored the best from these metrics had processes that:

- ◆ Were clearly defined;
- ◆ Addressed both initiatives and all phases of projects;
- ◆ Were consistently applied;
- ◆ Were endorsed by management.

These results highlight the points made earlier that initiative and project methodologies both need to be developed and communicated to the company. These methodologies also need to be applied equally to all projects to maintain the credibility of the IT PMO in the eyes of the business units. Also, a critical first step to the downfall of an IT PMO is when the executive committee fails to select projects for funding from the IT PMO prioritization list (i.e., steps outside the bounds of the initiative methodology). Such a move would be a clear sign that upper management is no longer supporting the IT PMO.

The survey also found that the businesses with higher scores used a hybrid of approaches that were very customized to their business rules. Even more specifically, the two areas in which the top 20% really excelled were [2]:

1. Portfolio balance—achieving the right balance of projects;
2. The right number of projects for the resources available.

Chapter 7 on resource management showed how to avoid project gridlock by constantly leveling the resources. If resources become too scarce, advanced scheduling measures such as critical chain can be used. This next section will present some methods that can help the IT PMO present a prioritized list of projects and initiatives to the executives that will best balance the portfolio.

9.5 Balance

9.5.1 Project Buckets

Earlier, we showed how project investments, as opposed to financial investments, add two elements to the “money out” output: improvements in efficiency and strategic redirection. These two output forms provide the basis for a very common way to categorize the projects in an IT portfolio: separate those projects that improve the efficiency of the company from those that support a redirection in the corporate strategy. Then, divide the “projects into two or three budgets based on the type of investment” [17]. One example would be to split the portfolio into three different budgets: utilities, incremental upgrades, and strategic investments (or *platform*, *evolutionary*, and *revolutionary* [18]) (see Figure 9.5). First, we create two sides of the project pendulum, called *improve efficiency* and *change business direction*. Then we add the buckets that support these two sides of the pendulum.

Chapter 1 explained that risk is the main determinant in deciding how to balance IT projects across the portfolio. At a high level, risks can change as the market changes. Because the strategies that allow projects to be funded change with the marketplace, the buckets themselves can never be statically defined. So, whenever a strategic shift occurs, the PMO would then need to start rebalancing the portfolio pendulum or

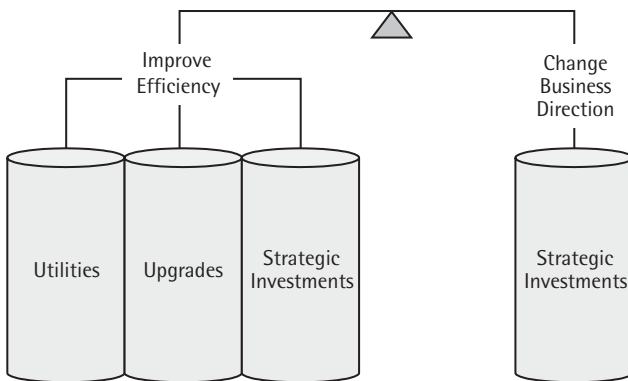

Figure 9.5 Balancing projects between efficiency improvement and strategic change.

start realigning “each project with its contribution to the [new] strategy” [18]. At a low level, risks can differ between the different buckets in the portfolio pendulum. For example, upgrades can be considered relatively low-risk *supporting systems*, and strategic investments can be considered high-risk *disruptive systems* [16].

The riskiness of the portfolio depends not only on the riskiness of its individual projects but also on the extent that they tend to go up and down together—their correlation or covariance. Rather than estimating individual variances, we should build models of technical or organizational covariances [28]. Rather than determining the risk of an IT project portfolio based just on how well risk is distributed among projects, we can determine overall risk based also on how well projects of like categories are progressing. In our case, we use portfolio buckets, balanced on the portfolio pendulum, as our risk covariance model. Figure 9.6 shows three different ways a PMO can bucket projects. It also shows how projects are distributed evenly across the buckets based on risk level. An unhealthy portfolio, on the other hand, would show a

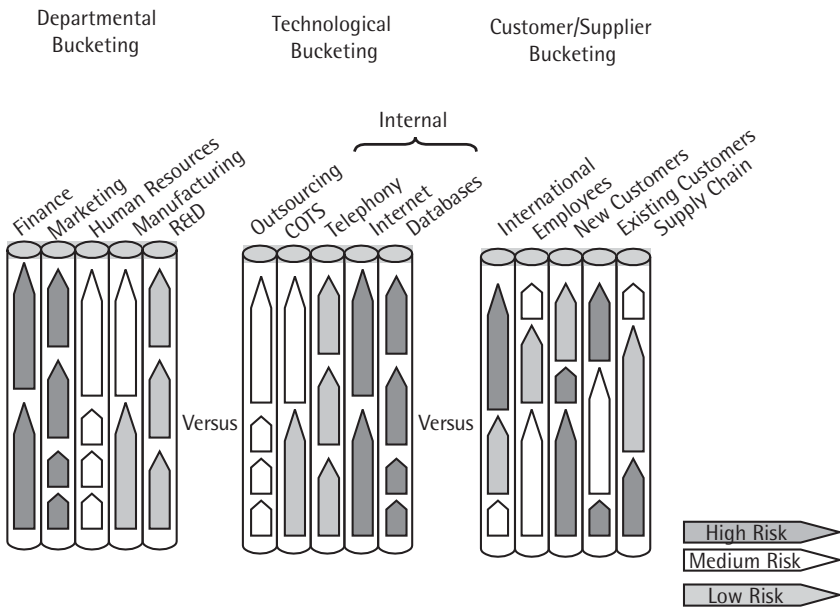

Figure 9.6 Approaches to bucketing projects of varying risk for balance.

preponderance of high-risk projects in one bucket and mostly low-risk projects in another.

Properly designing the buckets can be just as important as properly choosing which projects to finance. “Many companies create buckets associated with departments even though the desired bucket associations should be with customers and corporate strategies”[18]. A poorly chosen bucket suite can incorrectly show a lack of health. This could force the PMO to improperly recommend cancellation of some projects. If buckets are chosen well, on the other hand, some high-risk projects can be saved because the bucket design will show that they are well balanced by low-risk projects in the same bucket. In this case, we can see that a bucket design that focuses on department projects shows that the finance and marketing departments have adopted high-risk projects across the board. We can also see that Internet and database projects that have been financed are also all at high risk. However, a bucket design that focuses on customers, suppliers, and employees shows that the portfolio of project risks is well distributed. Some companies may lean towards certain bucket designs based on past experiences and on their markets. Either way, bucket design should be a part of the corporate strategy (or the EBA).

Figure 9.7 takes the bucket design based on risk mitigation of Figure 9.6 and overlays it with the bucket design based on strategic and efficiency balancing of Figure 9.5. As the company changes strategy (1), not only will the bucket designs need to change (2), but the amount invested in efficiency improvement versus business redirection will need to change. Figure 9.7 shows this by the shifts that can occur in the pendulum. If a company wants to focus more IT project funds on changing the direction of the company, then the pendulum will move to the right (3). This will cause the improvement efficiency side to drop (4). To regain a balance in the IT project portfolio, the PMO would then have to recommend canceling or delaying certain projects in utilities or upgrades. As one can see, such project risk categorization and balancing can be rather subjective. A way to reduce this subjectivity, when balancing the portfolio, is to include some of the metrics described in Section 9.5.2.

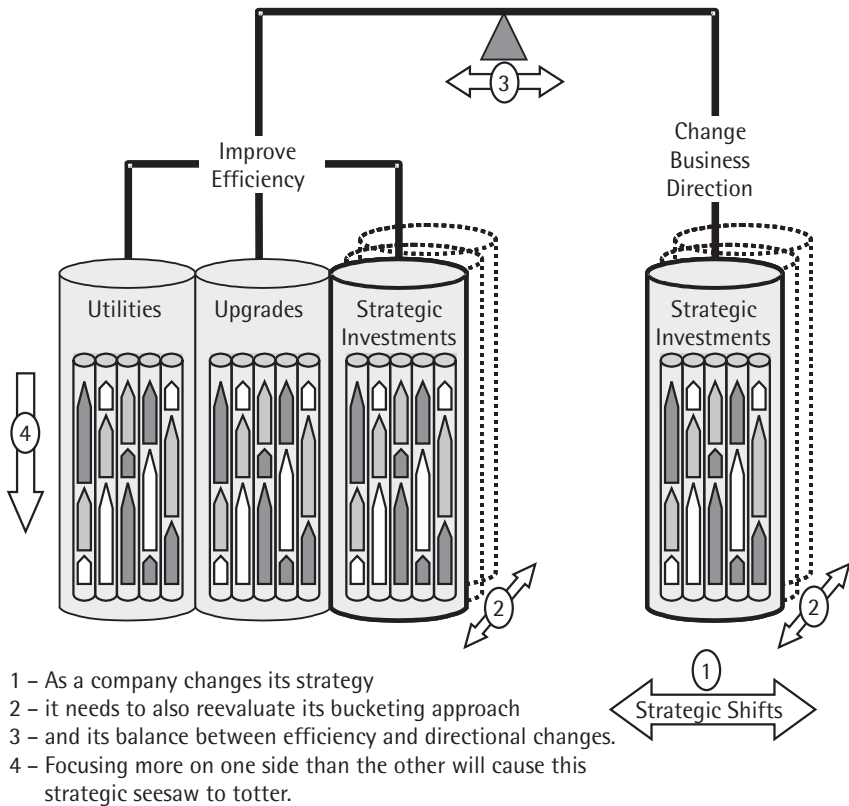

Figure 9.7 The need for dynamic bucket balancing.

9.5.2 Bubble Diagrams

A very popular way of keeping the cumulative project direction well balanced is through the use of bubble diagrams. Where scorecards will tabulate the values of various metrics for each project, bubble diagrams put these values into multidimensional space. This allows the prioritizing team to see value in a project beyond its total score in a scorecard. While a project may not rate high overall, the bubble diagram will show other strengths that may make the project more appealing than others.

A bubble diagram, otherwise known as a bubble chart or a *portfolio grid* [29], starts off with a two-dimensional graph. Some parameters that can be considered for the axis include resource availability, asset leverage, portfolio leverage, architectural alignment, fit with strategy,

cost to complete, and time to complete [26]. When using an X-Y type of grid, it is best to have a qualitative metric on one axis and a quantitative metric on another to help ensure the metrics' variables are independent. Once a grid type and the parameters are chosen, several techniques can be used to represent projects on the grid. Figures 9.8 and 9.9 show an example of Buss's technique for rank ordering projects, which uses four bubble charts concurrently [29].

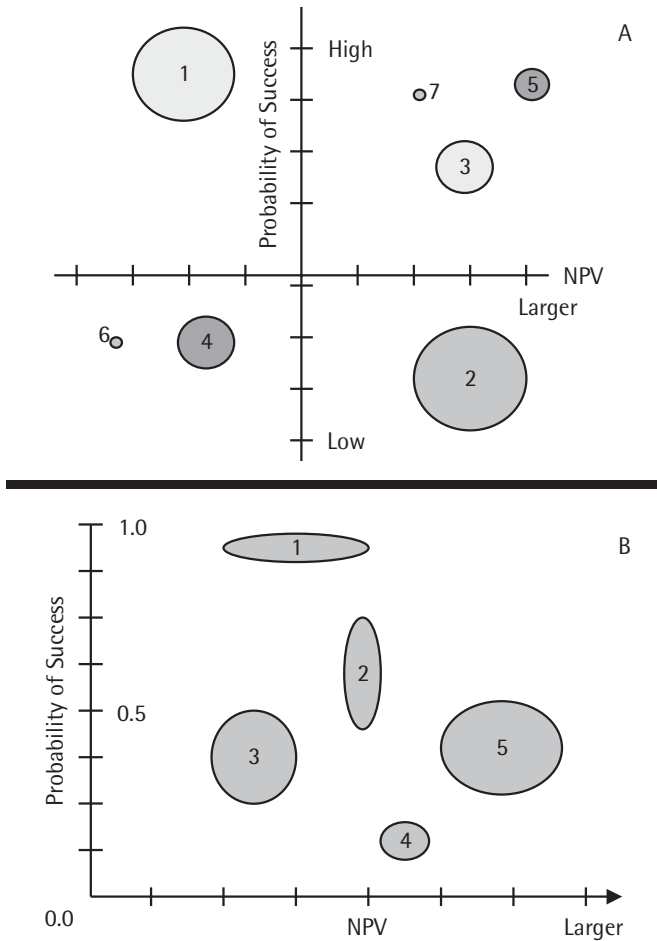

Figure 9.8 Other graphical approaches to balancing a project portfolio (A and B).

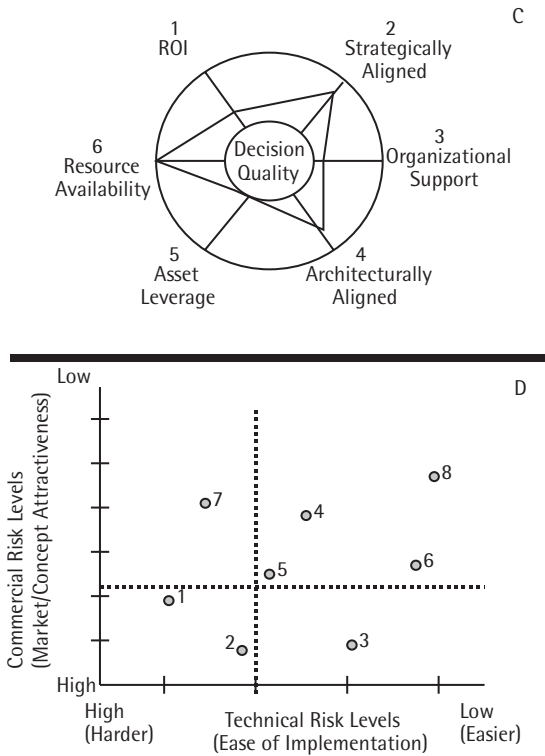

Figure 9.9 Other graphical approaches to balancing a project portfolio (C and D).

Chart A shows the Y axis as the qualitative *probability of success* metric and the X axis as the quantitative *NPV* metric. The areas of the circles represent resource usage. More advanced bubble diagrams will calculate the summation of the areas of the circles and ensure that this sum stays constant (representing the constant number of resources available to the portfolio). The colors can represent the state of the initiative (e.g., imminent launch or on hold) or the progress of the project (e.g., 50% complete or in rollout phase of last iteration). Rather than depict resource usage, chart B shows how the circles can become ovals to show range of error while calculating the metric values. Chart C shows a spider diagram depicting the relationship among six requirements for a single project. Though spider diagrams only represent one project, they show six dimensions (or metrics) at once. To compare projects using

this form of diagram will require the prioritizer to hold up multiple diagrams at once. Finally, the IT PMO can create a chart that includes hurdle gates. Chart D shows where the cutoff points are set for commercial risk levels (horizontal line to the Y-axis) and for technical risk levels (vertical line to the X-axis).

9.6 Summary

Keep in mind that bubble diagrams are not an end to the portfolio-balancing problem; they are meant to serve only as a decision-enabling tool. Another tool that assists with balancing is the bucket concept described earlier. A manager can stare at a set of diagrams forever, “but unless a portfolio was obviously and extremely out of balance, how does one know whether or not one has the right balance?” [26]. Ultimately, balancing the portfolio requires just as many subjective decisions as those used to estimate financial ROI and strategic alignment. The best mix and quantity of metrics depends on the individual company. We pointed out that some companies develop prioritization lists more aligned with qualitative measures, while others do better with quantitative measures. Cooper, Edgett, and Kleinschmidt’s survey showed that using more criteria is associated with better performing companies; “the top performers, on average, rely on 6.2 criteria for project selection, whereas the poor performers use only 4.4 criteria, on average” [8]. As long as each of the three prioritization approaches are represented, the IT portfolio can, at the same time, stay both flexible to strategic shifts and focused on corporate growth.

References

- [1] Crawford, J. Kent, *The Strategic Project Office*, Monticello, NY: Marcel Dekker, 2004.
- [2] Edgett, Scott, Elko Kleinschmidt, and Robert Cooper, “Portfolio Management in New Product Development: Lessons from the Leaders, Phase II,” in *Project Portfolio Management*, Lowell D. Dye and James S. Pennypacker, (eds.), West Chester, PA: Center for Business Practices, 1999, pp. 97–116.

- [3] Markowitz, Harry M., *Portfolio Selection*, London, England: Basil Blackwell, 1992.
- [4] Cleland, David, "The Strategic Context of Projects," in *Project Portfolio Management*, Lowell D. Dye and James S. Pennypacker, (eds.), West Chester, PA: Center for Business Practices, 2002, pp. 3–22.
- [5] Bridges, Dianne, "Project Portfolio Management: Ideas and Practices," in *Project Portfolio Management*, Lowell D. Dye and James S. Pennypacker, (eds.), West Chester, PA: Center for Business Practices, 2000, pp. 45–54.
- [6] Spring, Steve, Beebe Nelson, and Bob Gill, "Building on the Stage/Gate: An Enterprise-Wide Architecture for New Product Development," in *Project Portfolio Management*, Lowell D. Dye and James S. Pennypacker, (eds.), West Chester, PA: Center for Business Practices, 1999, pp. 87–96.
- [7] Ferranti, Marc, "Gartner—Align Thyself," *CIO Magazine*, November 15, 2001, <http://www.cio.com/archive/111501/align.html> (last accessed on January 15, 2004).
- [8] Edgett, Scott, Elko Kleinschmidt, and Robert Cooper, "Best Practices for Managing R&D Portfolios," in *Project Portfolio Management*, Lowell D. Dye and James S. Pennypacker, (eds.), West Chester, PA: Center for Business Practices, 1999, pp. 309–328.
- [9] Frame, J. Davidson, "Selecting Projects That Will Lead to Success," in *Project Portfolio Management*, Lowell D. Dye and James S. Pennypacker, (eds.), West Chester, PA: Center for Business Practices, 1999, pp. 169–182.
- [10] Tjan, Anthony K., "Finally a Way to Put Your Internet Portfolio in Order," *Harvard Business Review*, February 1, 2001, Reprint R0102E.
- [11] Keelin, Tom, and Paul Sharpe, "How SmithKline Beecham Makes Better Resource-Allocation Decisions," in *Project Portfolio Management*, Lowell D. Dye and James S. Pennypacker, (eds.), West Chester, PA: Center for Business Practices, 1999, pp. 329–338.
- [12] Pressman, Robert S., *Software Engineering: A Practitioner's Approach*, 3rd ed., New York: McGraw Hill, 1993.
- [13] Ghasemzadeh, Fereidoun, and Norman Archer, "Project Portfolio Selection Techniques: A Review and a Suggested Integrated Approach," in *Project Portfolio Management*, Lowell D. Dye and James S. Pennypacker, (eds.), West Chester, PA: Center for Business Practices, 1999, pp. 207–238.
- [14] Ghasemzadeh, Fereidoun, and Norman Archer, "An Integrated Framework for Project Portfolio Selection," in *Project Portfolio Management*, Lowell D. Dye and James S. Pennypacker, (eds.), West Chester, PA: Center for Business Practices, 1999, pp. 117–134.

-
- [15] Khurana, Anil, and Stephen R. Rosenthal, "Integrating the Fuzzy Front End of New Product Development," in *Project Portfolio Management*, Lowell D. Dye and James S. Pennypacker, (eds.), West Chester, PA: Center for Business Practices, 2001, pp. 339–362.
- [16] Kaplan, Jeffrey D., "White Paper: Strategically Managing Your IT Portfolio," *PRTM's Insight*, April 1, 2001, <http://www.prtm.com> (last accessed on January 15, 2004).
- [17] Berry, John, "Tools Bring ROI into Focus—Software That Calculates Return On Investment Helps Companies Determine," *Internet Week*, December 10, 2001, <http://www.portfoliomgt.org/ForumItem.asp?itemID=965> (last accessed on January 15, 2004).
- [18] Englund, Randall, and Robert Graham, *Creating an Environment for Successful Projects*, San Francisco, CA: Jossey-Bass, 2002.
- [19] Combe, Margaret W., "Project Prioritization in a Large Functional Organization," in *Project Portfolio Management*, Lowell D. Dye and James S. Pennypacker, (eds.), West Chester, PA: Center for Business Practices, 2000, pp. 363–370.
- [20] Pastore, Richard, "Noodling Numbers," *CIO Magazine*, May 1, 2000, <http://www.cio.com/archive/050100/advice.html> (last accessed on January 15, 2004).
- [21] Mayor, Tracy, "Value Made Visible," *CIO Magazine*, May 1, 2000, <http://www.cio.com/archive/050100/method.html> (last accessed on January 15, 2004).
- [22] Norton, David P., and Robert S. Kaplan, *The Strategy-Focused Organization*, Boston, MA: Harvard Business School Press, 2001.
- [23] Kutoloski, David M., and C. Thomas Spradlin, "Action-Oriented Portfolio Management," in *Project Portfolio Management*, Lowell D. Dye and James S. Pennypacker, (eds.), West Chester, PA: Center for Business Practices, 2000, pp. 261–270.
- [24] Mantel, Samuel, and Jack Meredith, "Project Selection," in *Project Portfolio Management*, Lowell D. Dye and James S. Pennypacker, (eds.), West Chester, PA: Center for Business Practices, 2001, pp. 135–168.
- [25] Reifer, Donald J., *Making the Software Business Case: Improvement by the Numbers*, Reading, MA: Addison-Wesley, 2004.
- [26] Kleinschmidt, Elko, Scott Edgett, and Robert Cooper, "Portfolio Management in New Product Development: Lessons from the Leaders, Phase I," in *Project Portfolio Management*, Lowell D. Dye and James S.

- Pennypacker, (eds.), West Chester, PA: Center for Business Practices, 1999, pp. 97–116.
- [27] Traynor, Ann Jensen, and Anne DePiante Henrikson, “A Practical R&D Project_Selection Scoring Tool,” in *Project Portfolio Management*, Lowell D. Dye and James S. Pennypacker, (eds.), West Chester, PA: Center for Business Practices, 1999, pp. 239–260.
- [28] Harder, Paul, “A Conversation with Dr. Harry Markowitz,” *Gantthead.com*, 2002, <http://www.eitforum.com/ForumItem.asp?itemID=1158>.
- [29] Menk, Michael, and J. Matheson, “Using Decision Quality Principles to Balance Your R&D Portfolio,” in *Project Portfolio Management*, Lowell D. Dye and James S. Pennypacker, (eds.), West Chester, PA: Center for Business Practices, 1999, pp. 61–70.
- [30] Low, Lafe, “How Citigroup Measures Up,” *CIO Magazine*, April 15, 2004, <http://www.cio.com/archive/041504/citigroup.html> (last accessed on June 25, 2004).

Appendix 9A: Case Study—CitiGroup—IT PPM Software

Many software companies have built software products that support IT PMOs (see the accompanying CD-ROM for a sample listing). However, rather than purchase a software package that provides IT PPM functionality, CitiGroup's Global Corporate and Investment Banking (GCIB) group built its own from scratch. The group's goal was to build a tool to automate many of the features normally found in an IT PMO. The internal product was called Mystic (short for my systems and technology information center) and provided the following functionality:

- ◆ *Project health status.* This is a *project prioritization system* that monitors the project portfolio in real time. PMs regularly enter the status of their projects so that executives can view summarization reports.
- ◆ *Citigroup technology catalog.* This is an *asset management system* that tracks CitiGroup's servers, network routers, and packaged applications.
- ◆ *CitiGroup systems inventory.* This is another *asset management system* that tracks custom, internally developed applications.
- ◆ *Customer satisfaction surveys.* This is a *knowledge management system* that allows for post-mortem input from the project sponsor on how the project staff performed.
- ◆ *Reusable asset manager.* This is a second *knowledge management system* that stores reusable software and project collateral.
- ◆ *Global talent manager.* This is a *resource management system* to track the skill levels of the IT talent available to support IT-based projects.

It took GCIB's CIO, Thomas Sanzone, over two years to roll this system out to the IT department to support the 15,000 ongoing projects. Since the initial rollout, project on-time delivery has improved 15%, while the number of projects has grown 50%. Not only is this system used to support current projects, it is also used to improve the portfolio at the initiative approval stage. While a CIO council has final approval on project funding, initiatives are first required to consult the

CitiGroup technology catalog in Mystic for approved and supported software. Such control helps reduce overall portfolio costs by ensuring architecture alignment and asset reuse within the project pipeline.

This approach to IT PPM rollout uses the IT department as a pilot department first before engaging the rest of the company. With organizational acceptance as the greatest hurdle to IT PPM success, any IT PPM initiative will have gained a solid advantage if it has worked out the technical kinks beforehand with such a pilot. An error-prone software solution that supports a grand organizational shift such as IT PPM can lead to severe backlash and ultimate failure. Besides smoothing out the quality of the system, Sanzone also understands that the Mystic system will need to allow for metrics to be more flexible to the various business units before rolling it out to non-IT sponsored technical projects. This is similar to the need for dynamic KPIs in the Balanced Scorecard (see Appendix 3A). In short, whether you buy or build an IT PPM software solution, be sure to couple its rollout with continual internal marketing and software quality assurance [30].